

Small Communities Decentralized Wastewater Treatment: Assessment of Technological Sustainability

Andrea G. Capodaglio, Arianna Callegari

Daniele Cecconet, Daniele Molognoni

University of Pavia, ITALY

- A**bout 50% of world's population lives in rural or peri-urban areas
- I**n the EU, 30% of former CEE Countries population lives in settlements of less than 2000 people (in the West, less than 20%)
- A** considerable portion of that population is still waiting for proper sanitation systems, or is aiming to improve the efficiency of existing ones and scale-up environmental protection and resources recovery
- C**entralized treatment systems for rural or peri-urban communities imply high investment costs: in low income countries (and not just!) this approach will result in long-term, often unsustainable, debt burden
- A** collection system could account alone for 80-90% of the total costs of a new centralized sewerage system

In addition to investment costs, centralized treatment systems use a very high fraction of the total energy consumption just for water transport (up to 80% of 0.3-1.0 kWh/m³ treated)

In both developed and developing countries, cities are losing their character of densely concentrated settlements and are sprawling to the countryside with resulting lower population density

Even in developed countries, in areas where construction of centralized sewage collection systems is not considered economically viable, decentralization is becoming popular: 25% of the population in the US is already served by small, decentralised WWTPs

The term decentralized also qualifies systems serving small portions (clusters) of the urban area, according to hydrology, landscape and local ecology considerations

A move to decentralized water management, could be essential in order to improve systems resiliency and efficiency, recover lost or diminished environmental functions, and achieve resource recovery

Most of the developed world urban water infrastructure is close or past its useful design lifespan (usually 50-60 years), and thus due to undergo substantial rehabilitation/refurbishment in the next decade, switching to smaller, cluster-base systems could not only be a sustainably-wise sensible solution, but, in the long term, a financially sound one, as well.

Decentralized wastewater treatment complies with water management paradigms change, from waste-oriented approach to resource-recovery and water reuse ones: decentralized sanitation focuses on on-site treatment and allows local recycling of resources contained in domestic wastewater, in primis, water itself. Other resources that can be readily recycled are: bio-energy, and nutrients

Decentralized Wastewater Treatment (DWT)

-treat and dispose small volumes of wastewater from single households or group of dwellings in close proximity, not served by a central sewer system

-first and simplest form of DWT consisted historically of anaerobic treatment (septic tank), settling suspended solids and achieving their anaerobic digestion. In hot climates, septic tanks can remove 60% or more of organic load but usually achieve little in the way of pathogen reduction

-waste stabilization ponds include anaerobic ponds, facultative ponds that combine aerobic and anaerobic processes, and purely aerobic maturation ponds. Obvious advantage of pond systems is their simplicity, and long retention times favour reduction of pathogen levels. They can also produce secondary economic benefits providing a environment for growing fish and nutrient-rich water for irrigation.

Advantages of DWTs

- effectively and efficiently treat domestic sewage to protect water quality, and support local water supplies, since wastewater is more likely to remain in the local watershed.
- make it easier for a community to implement local water reuse schemes for nondrinking purposes and, thus, reduce inappropriate demand for treated drinking water.
- advanced DWTs can achieve treatment levels comparable to centralized systems, minimizing the level of nitrates entering ground water
- most DWTs work by gravity flow rather than using energy to pump wastewater, reducing energy use
- often incorporate septic tanks at the source resulting in reduced costs and energy demand for treatment prior to land dispersal

Advantages of DWTs

- they can easily be scaled up to the needed size in communities with rapid growth, where installing new long distance pipelines to a central waste facility would be too expensive

- can be designed to meet specific treatment goals, handle unusual and peculiar site conditions, and to address local environmental protection requirements.

Thus, DWTs mostly comply with new paradigms for sustainable development, and may help communities reach the triple bottom line of sustainability:

***“good for the environment, good for the economy,
and good for the people” (US EPA)***

DWTs Technological Sustainability

-one of the most promising technologies in wastewater treatment are biologic, membrane filtration processes (MBRs) integrating biological degradation of pollutants with membrane filtration

-limitations inherent to MBR processes are: the cost of membranes themselves, and the progressive loss of membrane filtration capacity due to fouling.

-advantages include smaller footprint, high loading rate capabilities, modularity and disinfected/highly clarified effluent suitable for reuse

-MBR technology could play a prominent role in any DWT system

Filtration BCR Processes

The BCR consists of an aerobic reactor vessel, in which mixed liquor is kept in suspension by means of fine bubble aeration, positioned at the bottom of the vessel. The effluent from the BCR is filtered by a membrane-like medium with the purpose of separating the treated water from the biomass and keeping the latter within the reactor itself.

Due to the characteristics of the filter effluent filtration occurs by gravity only with a total head loss in the order of 2-3 cm



Reactor volume (total)	0.06 m ³
HRT (calculated, average)	2-2.4 d
Volumetric loading (COD)	0.35 kg/m ³ d
Membrane surface	1.24 m ²
Membrane type	Porex© corrugated radial cartridge
Membrane material	UHMWPE (Ultra-High Molecular Weight Polyethylene)
Pore size	20 µm
Dimensions of filter unit	15.5 cm (ext. diam.) x 25.4 cm (length)
Specific surface area	0.62 m ² /cartridge

Fine bubble aeration provides scouring energy to maintain the filter surfaces clean, however, the BCR is designed with the possibility of directing a counter-current, high pressure water/air flow from within the membrane, in order to unclog the filter medium should it become packed with biofilm. This feature was never used during the tests.

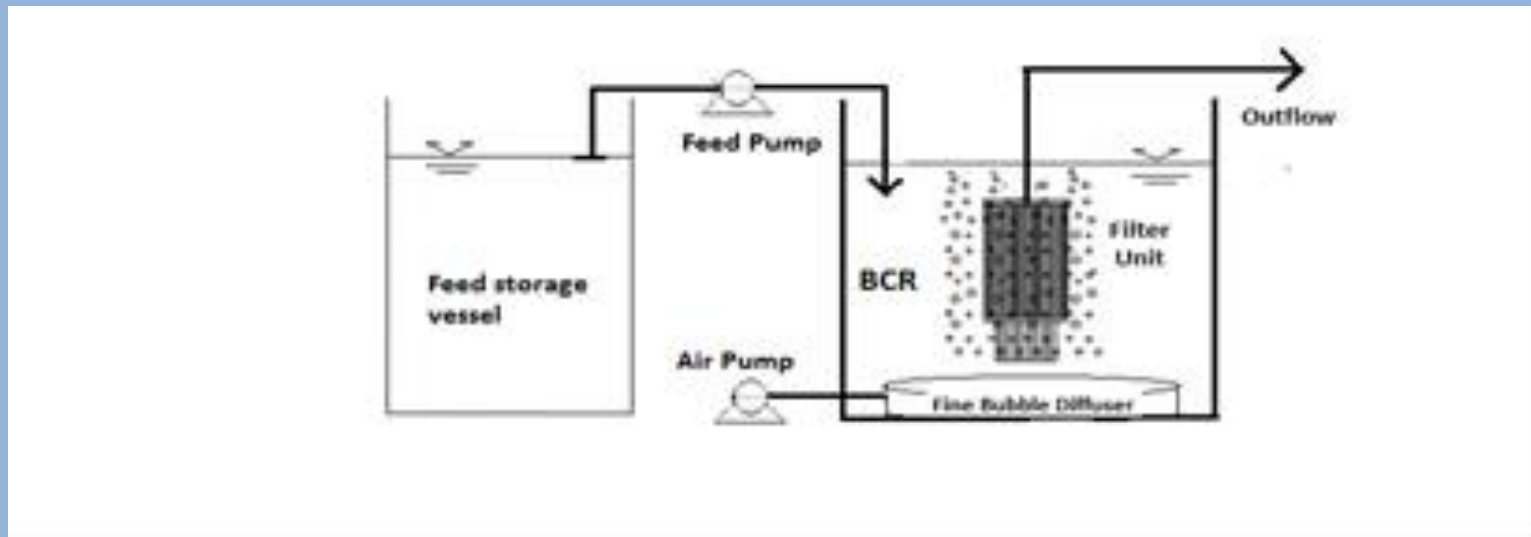

This technology is currently being tested according to German DIN standards for small, decentralized wastewater treatment plants.

-Chong et al. (2013) evaluated traditional MBR systems use in decentralized settings, versus energy requirements and GHG emissions of typical decentralized biofiltration systems

-They concluded that, considering also methane emissions from communal septic tanks, the overall GHGs emission balance could more or less be equivalent, while the sheer energy consumption of MBR systems was about threefolds that of traditional decentralized aerobic systems.

-The BCR process, in this respect, working by gravity flow only, positions itself energetically much closer a to traditional system than to a MBR, while still maintaining a good degree of filtration capacity (tests were performed with a 20 μm filter, but the same medium is commercially available with pore size down to 5 μm).

UASB (Upflow Anaerobic Sludge Blanket) systems are among the most used high-rate anaerobic digesters for treatment of wastewaters. Their design required some adaptation for practical application with domestic wastewater, that has typically lower COD concentrations, resulting in lower methane production, usually insufficient to heat the process reactors to the more favourable mesophilic temperature range (35-45°C).

Full scale UASB applications have shown excellent results under tropical conditions ($T > 20-25^{\circ}\text{C}$), with COD removal efficiencies around 75% at 6 hrs HRT, and are nowadays widely used in Brazil and other countries in South America, India, Indonesia and Egypt due to low construction and operational costs, even though their nutrient removal capability is low.

UASB application at lower temperatures is feasible, with performance limitations due to low hydrolysis rates, rather than to soluble COD conversion to methane.

In these conditions, biogas generation diminishes considerably with decreasing temperature, and about 50% of it may escape the system with the effluent, making its recovery unprofitable, save for local use of small isolated communities.

This is of secondary importance compared to the general economic benefits of the process for this type of applications, consisting of low initial investment, low energy for operation, lower sludge production and easier maintenance than conventional aerobic processes.

Sustainability is key to implement wastewater systems.

The main objectives of these systems are to protect and promote human health by providing a clean environment and breaking the cycle of disease.

In addition, resource and energy recovery can be considered.

The “most appropriate technology” in any situation is the one that turns out to be economically affordable, environmentally protective, technically and institutionally consistent and socially acceptable for the specific application.

When improving an existing and/or designing a new sanitation system, sustainability criteria related to the following aspects should be considered:

Health and hygiene (minimizing risk of exposure)

Environment and natural resources (energy, water and other resources required for construction and operation, as well as potential emissions resulting from use, including the degree of recycling and re-use)

Technology (maximizing functionality, ease with which the system can be constructed, operated and monitored. Robustness and vulnerability towards power cuts, water shortages, floods, etc. Flexibility/adaptability to existing infrastructure and demographic or socio-economic developments)

Financial and economic issues (capacity of households/communities to pay for the system)

Socio-cultural and institutional aspects (socio-cultural acceptance, convenience, perception, impact on human dignity, compliance with legal framework and institutional settings)

DWT	Health & Hygiene	Environment & Resources	Technology	Financial	Socio-cultural & Institutional
Constructed Wetlands	May be set up for solar disinfection (post-treatment)	Natural engineered systems. Energetically almost neutral. Good compatibility with sparsely populated locations. No resources recovery (but possible vegetation harvesting)	Easy to operate. High robustness and low vulnerability to crises. High adaptability if physically possible to expand. High water loss in hot climates.	Investment cost mostly for land plot. Operation close to free if gravity flow possible.	Acceptance good if “out of the way” and not causing nuisance. Possible poor institutional understanding (non standard practice)
Aerobic Conventional	Require post-treatment	Energy intensive. Current mainstream technology. Possibility of tertiary recovery of nutrients (struvite) and energy from sludge	Relatively easy to operate with remote control. Medium robustness and vulnerability (power cuts, discharge toxicity). Expandability possible at medium-high costs. Suitable for cheaper “package” construction for smaller facilities.	High investment and O&M costs (energy and sludge management).	Acceptance depending on location and past experience. Possible nuisance from odours. Well accepted institutionally.
MBR Aerobic	May be suitable for reuse without post-treatment	Very energy intensive. Smaller footprint than aerobic conventional. Higher efficiency. Possibility of tertiary recovery of nutrients.	More complex operation, with fouling problems in time. Robust towards flow and load variations, vulnerable to power cuts (medium), less to toxicity. Expansion requires high investments. Suitable for cheaper “package” construction for smaller facilities.	Highest investments and O&M (increased energy, but less sludge to manage)	Acceptance depending on location and past experience. Possible nuisance from odours. Accepted with cost-concerns institutionally
Aerobic Filtration	Will likely require post-treatment	Energy intensive (aeration). Footprint comparable to MBRs, similar efficiency.	Operation simpler than MBRs. Other conditions similar, lower investment for expansion. Suitable for cheaper “package” construction for smaller facilities.	Higher investment but O&M lower than MBRs. (less energy and sludge to manage)	Acceptance depending on location and past experience. Possible nuisance from odours. Accepted with cost-concerns institutionally
UASB	Require post-treatment	Anaerobic technology can be energy neutral or positive (biogas generation in the presence of strong wastes). Possibility of post-recovery of nutrients.	Relatively easy to operate at optimal conditions. Robust towards flow/load variations, vulnerability low. Expansion at medium cost. Suitable for cheaper “package” construction for smaller facilities.	Medium investment, Low O&M, sludge and effluent management. Possible high revenue from biogas recovery.	Acceptance depending on location and past experience, considering likely nuisance from odours. Cost-recovery (energy) enhances institutional support.

CONCLUSIONS

Decentralized/cluster wastewater treatment systems not only can reduce the effects of wastewater disposal on the environment and public health, but may also increase the ultimate reuse of wastewater.

When both centralized and decentralized systems are viable, the “most appropriate technology” should be selected, case-by-case, as the one that is economically affordable, environmentally sustainable and socially acceptable; management strategies should also be site specific.

Implementing decentralised technologies could give planners a chance to consider whether to also introduce source separation (urine/black/grey water) systems toilet or other extreme water saving systems (very low flush/vacuum) in order enhance resources and energy recovery.

In view of the necessity to reconstruct/refurbish/upgrade current centralised systems due to ageing, planners could find of interest to speculate upon alternatives to traditional wastewater treatment modes, possibly supporting the coexistence of various degrees of centralisation/decentralisation (satellite systems).

Currently, there is a good level of knowledge regarding implementation and performance of DWTs at the experts' and scientific levels, however, technological transfer into practice is still insufficient, and low awareness and recognition of DWTs benefits and a “business as usual” mentality still persist at the institutional and administrative levels.